

PN 5027
STK. NO. 19840

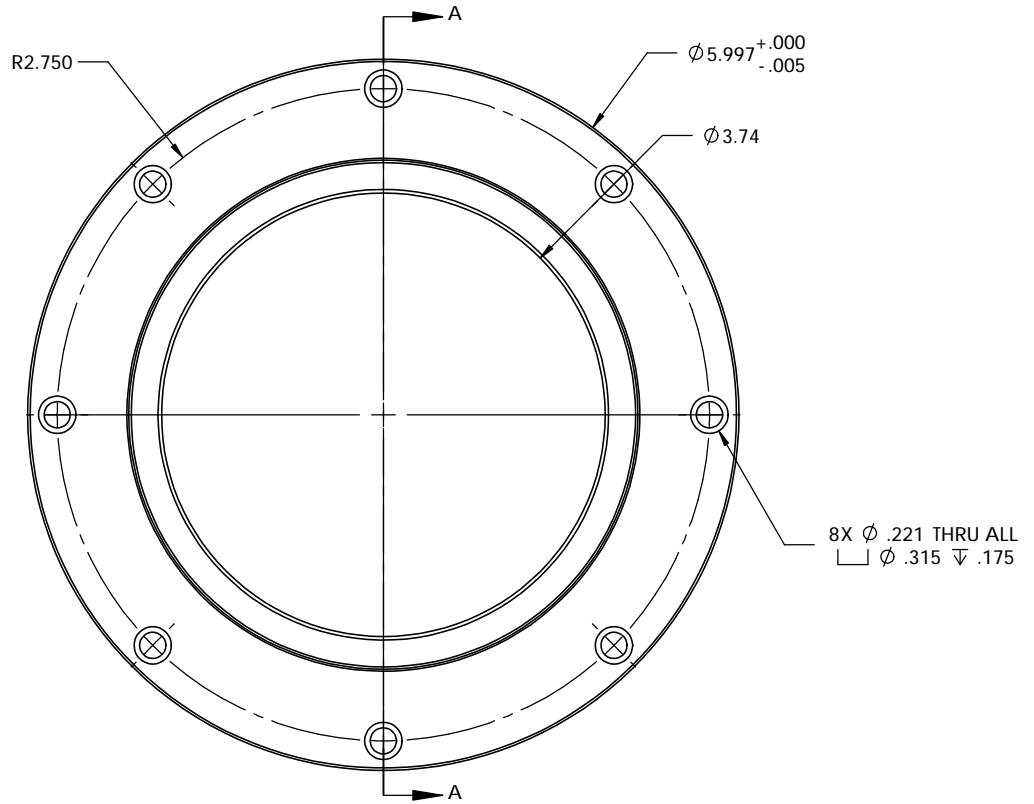
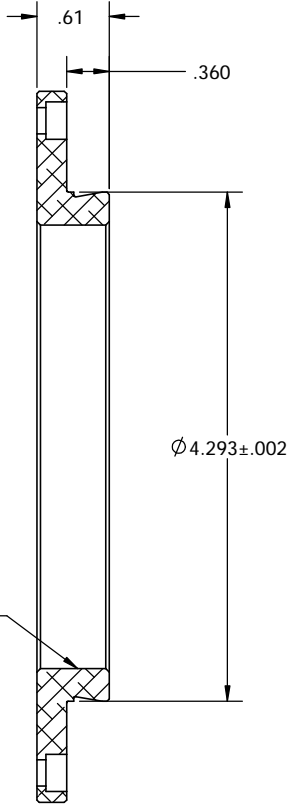

UNLESS OTHERWISE SPECIFIED: DIMENSIONS ARE IN INCHES TOLERANCES: FRACTIONAL ± ANGULAR: MACH ± BEND ± TWO PLACE DECIMAL ±.007 THREE PLACE DECIMAL ±.003	DRAWN	NAME	DATE	Optec Inc.
	CHECKED	LD	01/06/10	
	ENG APPR.			
	MFG APPR.			
	Q.A.			TITLE: CERAVOLO CDK MOUNT
THIRD ANGLE PROJECTION	MATERIAL 6061-T6	CONTRACT OPTEC-4300		SIZE DWG. NO. B 17-06721
FINISH FROSTKOTE BRIGHT DIP BLACK				SCALE: 1:1 WEIGHT: SHEET 1 OF 1
DO NOT SCALE DRAWING				